

LUG TYPE BUTTERFLY VALVE Z 414

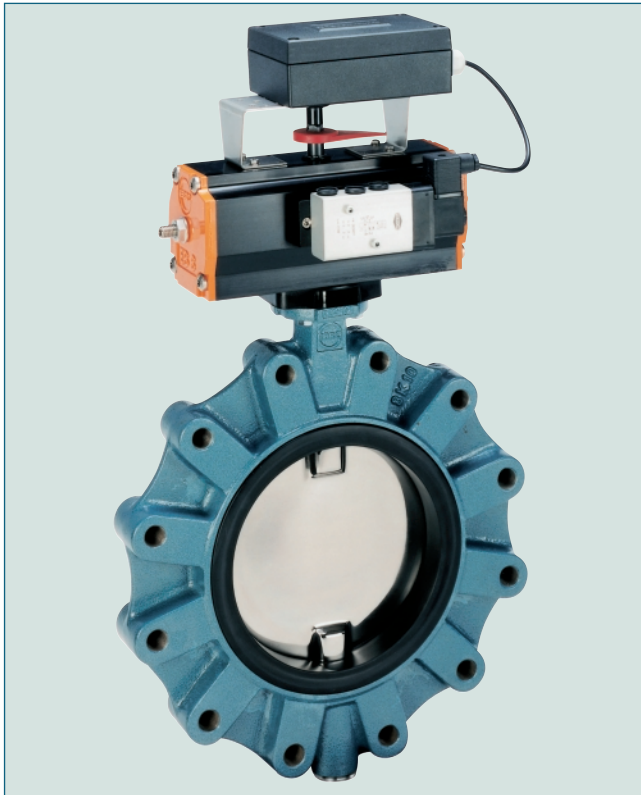

Resilient seated, centrally mounted lug type butterfly valve with reduced inside diameter for PE/PP piping systems.

TECHNICAL DATA

Nominal diameter:	da 63 – da 630 DN 50 – DN 600
Face-to-face:	EN 558 Series 20 (DIN 3202 T3 K1) ISO 5752 Series 20 API 609 Table 1 BS 5155 Series 4 NF E 29-305.1
Flange accommodation:	DIN 2501 PN 10
Top flange:	prepared for EN ISO 5211
Marking:	DIN EN 19
Tightness check:	DIN 3230 T3 BO, BN (Leakage Rate 1)
Temperature range:	-10 °C to +160 °C (depending on pressure, medium and material)
Operating pressure:	max. 10 bar SDR 11 (PE-80) max. 10 bar SDR 17,0 (PE-100) max. 6 bar SDR 17,6 (PE-80)
Vacuum:	0,2 bar absolute (depending on medium and temperature)

FEATURES

- Conformist butterfly valve for PE/PP piping systems.
- The disc diameter corresponds to the inside diameter of PE HD and PP pressure pipes.
- Short stub ends must not be removed by boring. The plant reliability will not be reduced.
- There is no need to manufacture and install complicated spacers.
- Can be mounted in any desired position.
- Triple shaft bearings prevent shaft deflection and guarantee optimum guidance even after many years of operational service.
- Interchangeable seat
- Maintenance-free
- Can be disassembled, material-specific recycling possible.

GENERAL APPLICATIONS

Where PE/PP pipes are used.

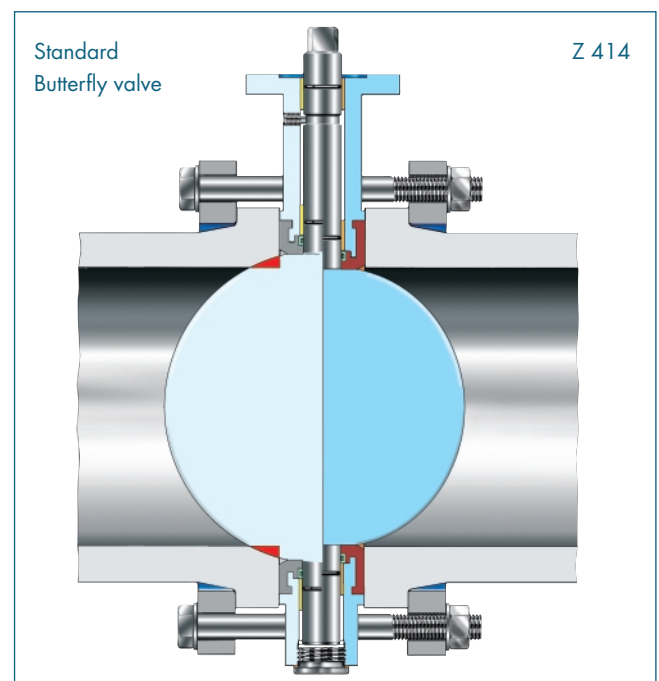

LUG TYPE BUTTERFLY VALVE Z 414

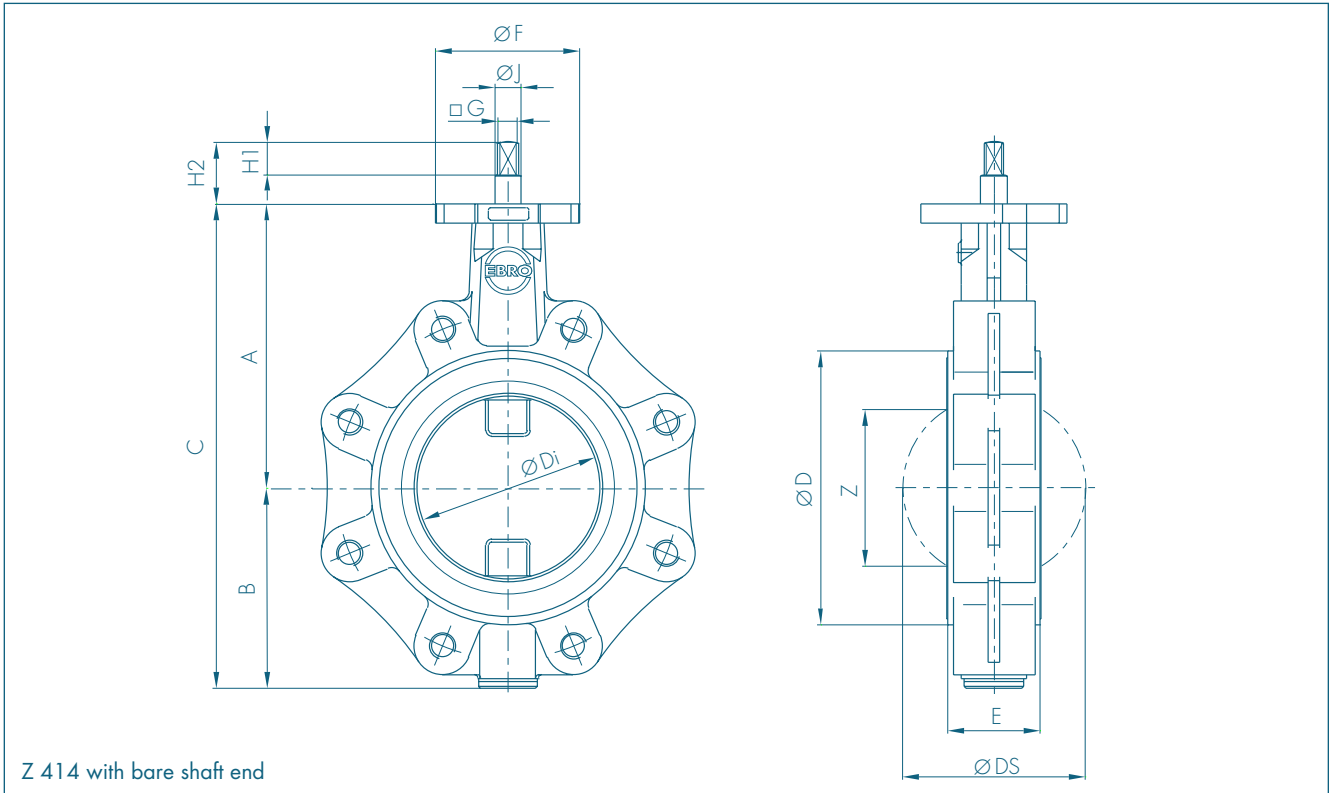

da [mm]	DN [mm]	Size [in]	Dimensions [mm]															Weight [kg]	
			A	B	C	D	Di	DS	E	F	Flange	G	H1	H2	J	Z	Splitted Shaft	TS- Shaft	
63	50	2	126	84	210	95	48	50	43	65	F05	10	16	30	12	25	5,0	-	
75	65	2½	134	93	227	115	63,5	65	46	65	F05	10	16	30	12	45	6,3	-	
90	80	3	157	104	261	130	79	80	46	90	F07	12	20	38	16	65	8,8	-	
110	100	4	167	115	282	150	98	99	52	90	F07	12	20	38	16	85	10,5	-	
125	100	4	167	115	282	150	98	99	52	90	F07	12	20	38	16	85	11,1	-	
140	125	5	174	121	295	168	111,1	112	56	90	F07	12	20	38	16	97	12,4	-	
160	150	6	180	142	322	180	123	124	56	90	F07	12	20	38	16	111	15,2	-	
180	150	6	203	150	353	206	148	149	56	90	F07	16	20	38	20	138	16,0	-	
200	200	8	203	176	379	206	151	149	56	90	F07	16	20	38	20	138	19,5	-	
225	200	8	221	176	397	250	181,5	183	60	90	F07	16	20	38	20	173	20,8	-	
250	250	10	228	205	433	250	198	199	60	90	F07	16	20	38	30	190	26,2	28,0	
280	250	10	266	212	478	315	224	225	68	125	F10	24	20	38	30	215	31,0	34,0	
315	300	12	271	230	501	360	255	256	78	125	F10	24	20	38	30	244	39,3	42,8	
355	350	14	293	261	554	350	279,3	281	78	125	F10	24	20	38	30	270	47,0	50,0	
400	400	16	363	304	667	428	327	328	102	150	F12	*	*	*	30	312	74,0	80,0	
450	500	20	410	353	763	408	338	338	78	150	F12	*	*	*	30	330	92,0	99,0	
500	500	20	437	359	796	507	408	410	127	210	F16	*	*	*	40	390	115,0	124,0	
560	600	24	475	418	893	530	426	427	114	210	F16	*	*	*	50	412	147,0	160,0	
630	600	24	475	418	893	574	488	490	127	210	F16	*	*	*	50	473	167,0	183,0	

* according to the mounted actuator

Subject to change without notice.

ACTUATORS Z 414

HAND LEVER

da [mm]	DN [mm]	Size [in]	Hand Lever	F	H	L	Weight [kg]
63-75	50-65	2 1/2-3	Size I	65	77	165	0,4
90-140	80-125	3 1/2-5 1/2	Size II	90	95	195	0,7
160-225	150-200	6 1/2-9	Size III	90	105	276	0,7

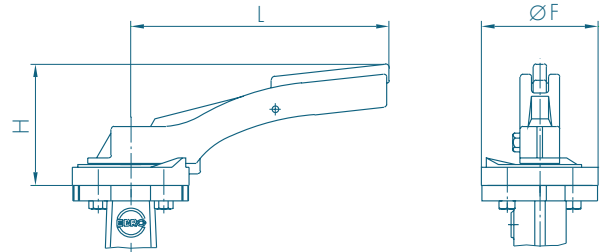

WORM GEAR

da [mm]	DN [mm]	Size [in]	Gear	H	J	K	L	Weight [kg]
63-140	50-125	2-5	Size II	89	39	125	159	1,4
160-250	150-250	6-10	Size III	129	47	200	202	2,3
280	250	10	Size IV	129	60	200	252	2,8
315-355	300-350	12-14	Size V	158	76	250	280	6,3
400-450	400-500	16-20	Size VI	228	90	356	322	16,0
500-560	500-600	20-22	Size VII	278	123	457	406	30,5
630	600	24	Size VIII	355	154	610	466	45,0

The dimensioning of actuators refers to an operating pressure of 10 bar.

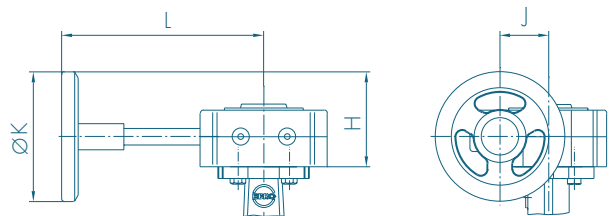

ELECTRIC ACTUATOR

da [mm]	DN [mm]	Size [in]	Actuator Type	Weight [kg]						
				H	J/DC	J/AC	K	L	M	
63-200	50-200	2-8	E 60	158	171	171	62	82	110	5,0
225-315	200-300	8-12	E 100	183	206	246	74	121	131	11,5
355-450	350-500	14-20	E 150	200	238	278	105	189	155	21,0
500-630	500-600	20-24	E 200	212	313	313	124	283	220	34,0

AC = Alternating current
DC = Three phase current

The dimensioning of actuators refers to an operating pressure of 10 bar.

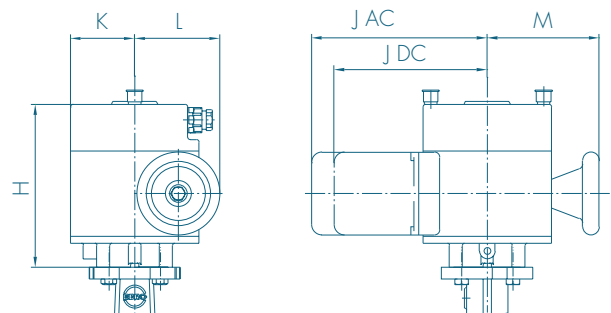

Subject to change without notice.

ACTUATORS Z 414

PNEUMATIC DOUBLE ACTING

da [mm]	DN [mm]	Size [in]	Actuator Type	H	J	K	L	Weight [kg]
63-75	50-65	2-2 ¹ / ₂	EB 4	111	74	49	145	1,3
90-125	80-100	3-4	EB 5	123	88	55	174	1,9
140-180	125-150	5-6	EB 6	142	103	62	208	3,0
200-225	200	8	EB 8	155	115	68	250	4,7
250-280	250	10	EB 10	174	135	79	312	7,4
315-400	300-400	12-16	EB 12	201	159	94	367	12,6
450-500	500	20	EB 265	232	152	76	390	18,0
560	600	24	EB 270	278	220	110	445	32,0
630	600	24	EB 280	278	220	110	600	42,0

The dimensioning of actuators refers to the following operating conditions:

Control air Pressure: 6 bar

Operating Pressure: DN 50 - DN 300 10 bar

DN 350 6 bar

DN 400 - DN 600 3 bar

Dimensioning for other conditions: upon request

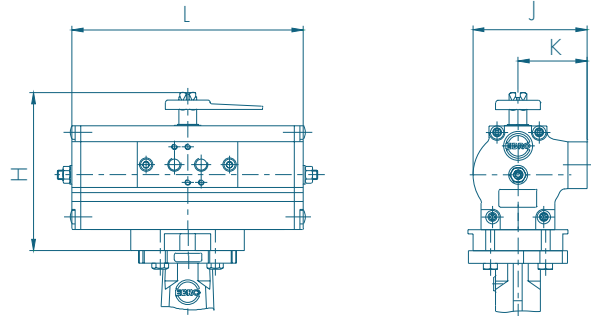

PNEUMATIC SPRING RETURN

da [mm]	DN [mm]	Size [in]	Actuator Type	H	J	K	L	Weight [kg]
63-90	50-80	2-3	EB 5	123	88	55	273	3,2
110-140	100-125	4-5	EB 6	142	103	62	326	5,4
160-200	150-200	6-8	EB 8	155	115	68	389	8,1
225-250	200-250	8-10	EB 10	174	135	79	526	14,9
280	250	10	EB 12	201	159	94	656	26,0
315-355	300-350	12-14	EB 265	232	152	76	634	27,0
400	400	16	EB 270	278	220	110	655	45,0
450-500	500	20	EB 280	278	220	110	1020	68,0

The dimensioning of actuators refers to the following operating conditions:

Control air Pressure: 6 bar

Operating Pressure: DN 50 - DN 300 10 bar

DN 350 6 bar

DN 400 - DN 600 3 bar

Dimensioning for other conditions: upon request

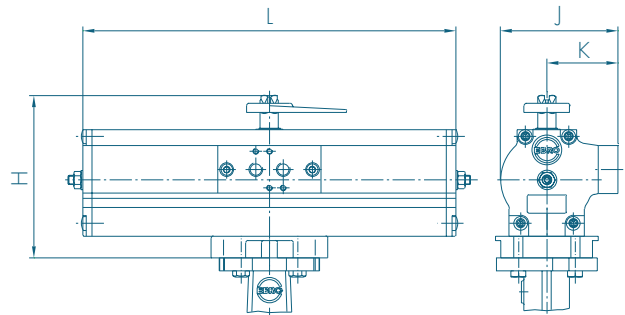

SWITCH BOX SERIES MSK/NSK

MSK: Switch Box with integrated micro limit switches.

NSK: Switch Box with integrated proximity switches.

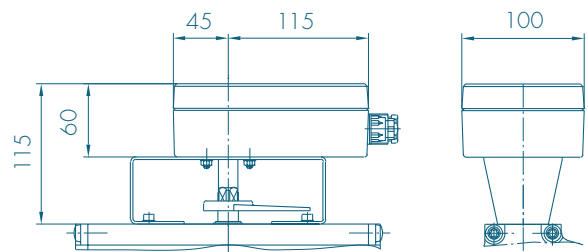

Subject to change without notice.

LUG TYPE BUTTERFLY VALVE Z 414

MATERIAL SPECIFICATION AND PARTS LIST

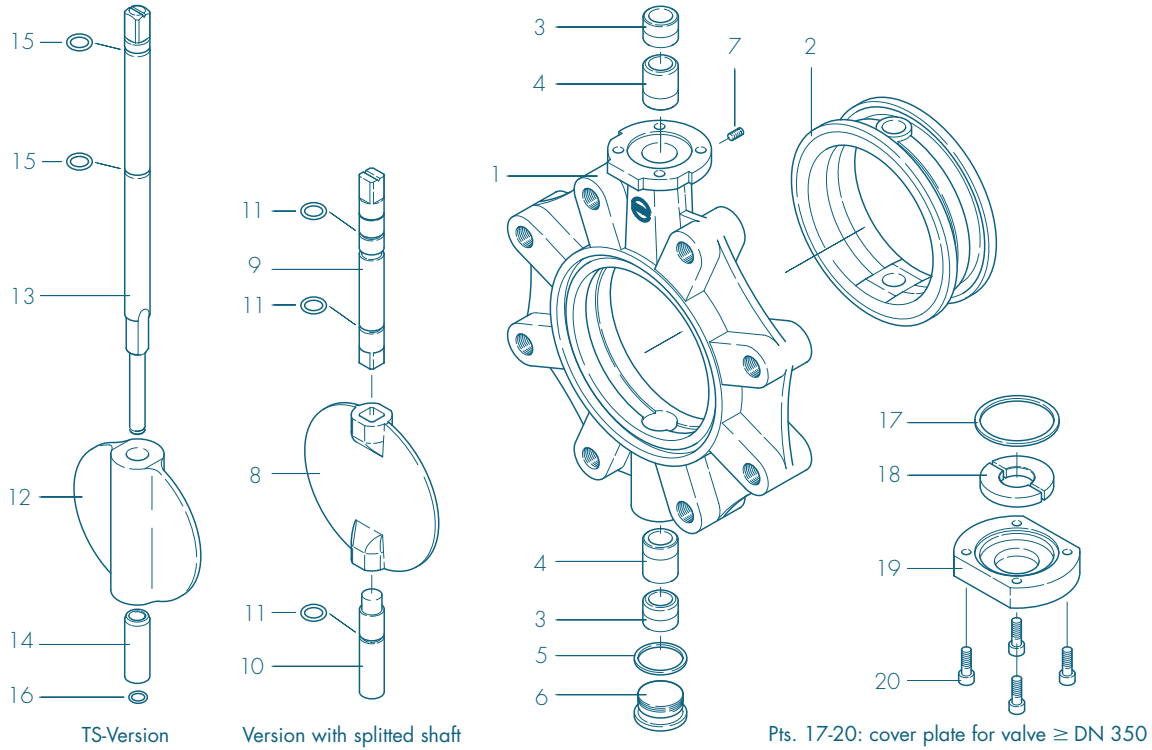

Pt.	Description	Material	Material-No.	ASTM	Pt.	Description	Material	Material-No.	ASTM
1	Body				12	TS-disc da250-da630			
	Nodular Cast Iron	GGG-40	0.7045	60-40-18		Nodular Cast Iron	GGG-40	0.7040	60-40-18
2	Seat					Stainless Steel	X6CrNiMo10-20	1.4408	CF8M
	NBR	Acrylonitrile butadiene rubber				Aluminium Bronze	CuAl10Ni	2.0975	C 95800
	EPDM	Ethylene propylene caoutchouc				Coating	Halar, Rilsan		
	FPM	Fluorocarbon caoutchouc				Surface Quality			
3/4	Bearing bush						electropolished, mirror finished		
	Brass	MS 58	2.0401	B 45	13	TS-shaft da250-da630			
	Polyamid					Stainless Steel	X14CrMoS17	1.4104	430F
5	Seal DIN 7603						X39CrMo17-1	1.4122	
	Stainless Steel	X5CrNiMo17-12-2	1.4401	316			X5CrNiMo17-12-2	1.4401	316
	PTFE	Cu			14	Sleeve			
	Copper			Copper		Stainless Steel	X5CrNi18-10	1.4301	304
6	Plug screw DIN 908				15	O-ring			
	Stainless Steel	G-X6CrNiMo 18-10	1.4408	CF8M		NBR	Acrylonitrile butadiene rubber		
7	Set screw DIN 915					FPM	Fluorocarbon caoutchouc		
	Steel	45 H galvanized			16	Retaining ring			
	Stainless Steel	A4-70		B8M		Stainless Steel	X39CrMo17-1	1.4122	
8	Disc				17	O-ring da400-da630			
	Stainless Steel	X5CrNi18-10	1.4301	304		NBR	Acrylonitrile butadiene rubber		
		X5CrNiMo18-10	1.4401	316	18	Shaft retainer da400-da630			
		G-X6CrNiMo18-10	1.4408	CF8M		Brass	MS 58	2.0401	B45
	Coating	Halar, Rilsan			19	Cover plate da400-da630			
	Surface Quality	electropolished, mirror finished				Grey Cast Iron	GG-25	0.6025	40 B
9/10	Shaft				20	Screw da400-da630			
	Stainless Steel	X14CrMoS17	1.4104	430F		Steel	45 H galvanized		
		X5CrNiMo17-12-2	1.4401	316		Stainless Steel	A2-70		B8
							A4-70		B8M
11	O-ring								
	NBR	Acrylonitrile butadiene rubber							
	FPM	Fluorocarbon caoutchou							
									Other materials upon request.

Subject to change without notice.

LUG TYPE BUTTERFLY VALVE Z 414

TORQUE

- The torque values specified (Md) are based on liquid and lubricant media.
 - Powdery (non-lubricant) media Md x 1,3
 - Dry gases/high viscous media Md x 1,2
 - The values specified are based on the initial breakaway torque.
 - Dynamic torque specification available upon request.
- Regarding the dimensioning of actuators please contact our engineers.

da [mm]	DN [mm]	Size [in]	Operating pressure		
			3 [bar]	6 [bar]	10 [bar]
63	50	2	4	7	10
75	65	2½	6	9	13
90	80	3	7	10	14
110	100	4	8	18	29
125	100	4	8	18	29
140	125	5	14	28	48
160	150	6	14	28	48
180	150	6	22	48	78
200	200	8	22	48	78
225	200	8	40	90	140
250	250	10	58	110	190
280	250	10	90	180	280
315	300	12	110	220	360
355	350	14	165	330	570
400	400	16	210	450	740
450	500	20	255	520	880
500	500	20	340	710	1150
560	600	24	470	965	1580
630	600	24	670	1300	2000

All values in Nm

K_V-VALUES

- The K_V-value (m³ per hour) is the flow of water at a temperature of 5 °C to 30 °C (41 °F to 86 °F) at Δp of 1 bar.
 - The K_V-values specified are based on tests carried out by the Delfter Hydraulics Laboratories, the Netherlands.
 - Permissible velocity of flow
V_{max} 4,5 m/s for liquids and
V_{max} 70 m/s for gases.
 - The throttle function is linear at an angle 30° to 70°.
 - Avoid cavitation!
- For further values, please contact our engineers.

da [mm]	DN [mm]	Size [in]	Opening angle α°							
			20°	30°	40°	50°	60°	70°	80°	90°
63	50	2	1,2	8	13	22	38	50	65	85
75	65	2½	2	9	22	42	77	115	170	215
90	80	3	8	24	50	95	150	240	330	420
110	100	4	13	28	65	130	180	340	550	800
125	100	4	13	28	65	130	180	340	550	800
140	125	5	26	65	130	230	350	530	870	1010
160	150	6	26	65	130	230	350	530	870	1010
180	150	6	35	90	200	360	640	900	1350	2100
200	200	8	35	90	200	360	640	900	1350	2100
225	200	8	40	140	280	480	800	1400	2500	3400
250	250	10	43	180	350	580	1000	1600	3000	4000
280	250	10	100	280	480	880	1500	2600	4500	5200
315	300	12	125	360	660	1100	1800	3100	5300	6400
355	350	14	200	550	1000	1600	2600	5000	7500	8500
400	400	16	250	620	1100	1720	2900	6000	8600	9400
450	500	20	350	780	1400	2400	4000	8000	10800	11500
500	500	20	490	1050	1800	3100	5500	11000	12000	14500
560	600	24	500	1080	2000	3300	5800	11500	13500	17000
630	600	24	520	1100	2200	3500	6200	12000	15100	21000

Subject to change without notice.