

HIGH-PERFORMANCE BUTTERFLY VALVE HP 111



Wafer type butterfly valve in double eccentric construction. Reliable sealing even with extreme temperature and pressure conditions.

TECHNICAL DATA

Nominal diameter:	DN 50 – DN 600 larger nominal diameter on request
Face-to-face:	EN 558 Series 20 (DIN 3202 T3 K1) ISO 5752 Series 20 (DIN 3202 T3 K1) API 609 Table 1 BS 5155 Series 4 NF E 29-305.1
Flange accommodation:	DIN 2501 PN 10/16/25/40 (to DN 150) DIN 2501 PN 10/16/25 (DN 200-600) DIN 2632/33/34/35 ANSI B 16.5, Class 150 MSS SP44 Class 150 AWWA C 207 AS 2129 Table D and E BS 10 Table D und E JIS B 2211-5 K JIS 2212-10 K
Flange Surface Design:	DIN 2526, Form A-E, ANSI RF
Top flange:	EN ISO 5211 NF E 29-402
Marking:	DIN EN 19
Tightness check:	
- for R-PTFE Sitz:	DIN 3230-BO (Leakage Rate 1)
- for Inconel Sitz:	DIN 3230-BN (Leakage Rate 1) ISO 5208, Category 3 API 598 Table 5 ANSI B 16-104, Class VI
Temperature range:	-40 °C to + 450 °C higher temperatures on request
Differential pressure:	≤ DN 150 max 40 bar > DN 150 max. 25 bar
Vacuum:	0,2 bar absolute (depending on medium and temperature)

FEATURES

- Shut-off and control of gaseous and liquid media
- Disc and shaft have double-eccentric bearing.
- Centering pieces can be used as installation aid.
- Two seat ring systems available: R-PTFE and Inconel
- Seal variants:
soft-sealing (R-PTFE) 230 °C max.
metallic sealing (Inconel) 450 °C max.
- Maintenance-free
- Long service life, even at high switching frequencies

GENERAL APPLICATIONS

- Chemical and petrochemical industries
- Hot water and steam systems
- District heat supply
- Vacuum systems
- Shipbuilding
- Gas process technology
- Heavy duty services

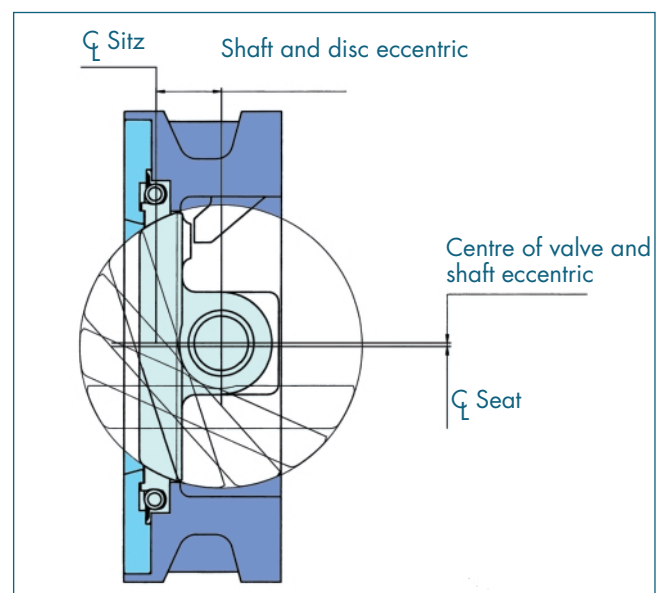

HIGH-PERFORMANCE BUTTERFLY VALVE HP 111

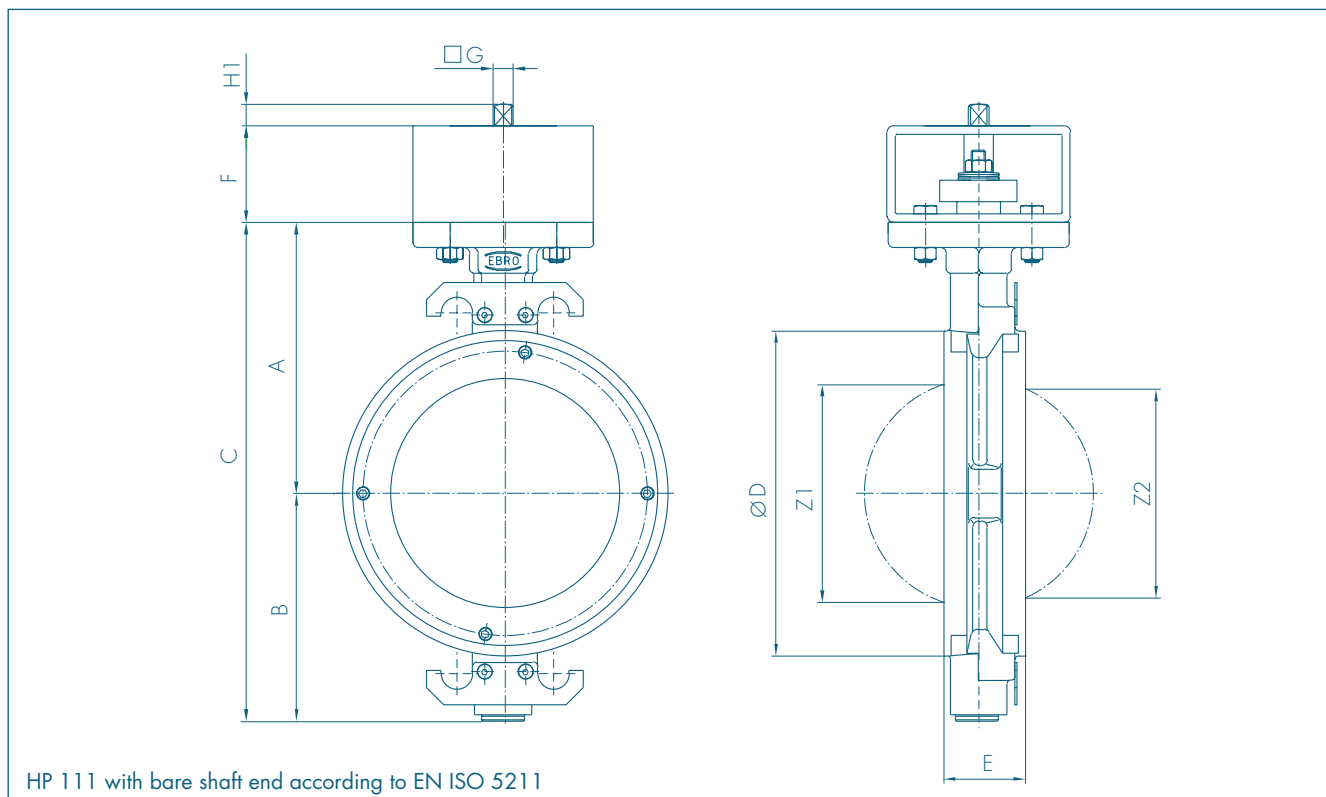

DN [mm]	Size [in]	Dimensions [mm]											min. Pipe-Ø	Weight [kg]
		A	B	C	D	E	F	Flange	G	H1	Z1	Z2		
50	2	133	99	232	112	43	80	F05	12	15	40,9	-	51	7,4
65	2½	133	99	232	112	43	80	F05	12	15	40,9	-	51	7,4
80	3	142	113	255	138	46	80	F05	12	15	70,7	54,4	80	8,0
100	4	158	124	282	160	52	80	F05	12	15	94,2	81,6	103	8,6
125	5	181	140	321	192	56	80	F07	14	18	114,5	105,3	124	12,6
150	6	195	154	349	216	56	80	F07	14	18	143,5	135,4	151	14,8
200	8	225	191	416	270	60	80	F10	17	18	187,4	181,2	196	22,9
250	10	268	222	490	326	68	80	F12	22	23	235,2	228,8	245	33,5
300	12	300	255	555	378	78	90	F12	27	28	280,7	275,8	296	48,0
350	14	345	304	649	438	92	100	F14	27	28	322,8	315,9	334	94,7
400	16	375	339	714	488	102	100	F14	36	36	371,6	363,9	385	115,0
450	18	412	340	752	530	114	120	F16	36	36	426,8	426,8	438	141,0
500	20	425	399	824	593	127	120	F16	46	46	468,7	466	484	186,0
550	22	456	405	861	635	154	200	F25	46	46	525,7	525,7	540	236,0
600	24	490	468	958	692	154	200	F25	55	55	544,5	542,2	560	310,0

Subject to change without notice.

ACTUATORS HP 111

WORM GEAR FOR PTFE-SEAT

DN [mm]	Size [in]	Hand Lever	H	J	K	L	Weight [kg]
50-125	2-5	Size II	89	39	125	159	1,4
150	6	Size III	129	47	200	202	2,3
200	8	Size IV	129	60	200	252	2,8
250-300	10-12	Size V	158	76	250	280	6,3
350	14	Size XII	192	67	300	295	10,1
400-500	16-20	Size VI	228	90	356	322	16,0
550-600	22-24	Size VIII	355	154	610	466	45,0

FOR INCONEL-SEAT

DN [mm]	Size [in]	Gear	H	J	K	L	Weight [kg]
50-100	2-4	Size II	89	39	125	159	1,4
125-150	5-6	Size III	129	47	200	202	2,3
200-250	8-10	Size V	158	76	250	280	6,3
300-350	12-14	Size XII	192	67	300	295	10,1
400	16	Size VI	228	90	356	322	16,0
450-500	18-20	Size VII	278	123	457	406	30,5
550	22	Size VIII	355	154	610	466	45,0
600	24	Size XIII	371	60	610	486	57,0

The dimensioning of actuators refers to an operating pressure of 10 bar.

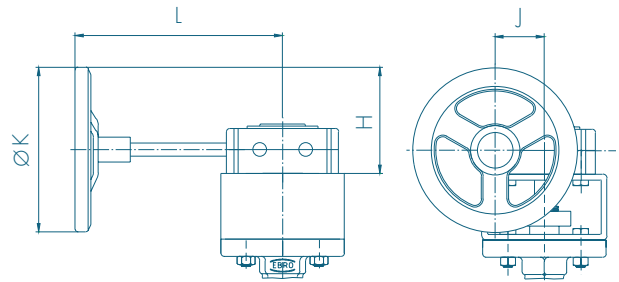

ELECTRIC ACTUATOR FOR PTFE-SEAT

DN [mm]	Size [in]	Actuator Type	H	J/DC	J/AC	K	L	M	Weight [kg]
50-125	2-5	E 60	158	171	171	62	82	110	5,0
150-200	6-8	E 100	183	206	246	74	121	131	11,5
250-350	10-14	E 150	200	238	278	105	189	155	21,0
400-500	16-20	E 200	212	313	313	124	283	220	34,0

FOR INCONEL-SEAT

DN [mm]	Size [in]	Actuator Type	H	J/DC	J/AC	K	L	M	Weight [kg]
50-100	2-4	E 60	158	171	171	62	82	110	5,0
125-200	5-8	E 100	183	206	246	74	121	131	11,5
250-350	10-14	E 150	200	238	278	105	189	155	21,0
400-500	16-20	E 200	212	313	313	124	283	220	34,0

AC = Alternating current
DC = Three phase current

The dimensioning of actuators refers to an operating pressure of 10 bar.

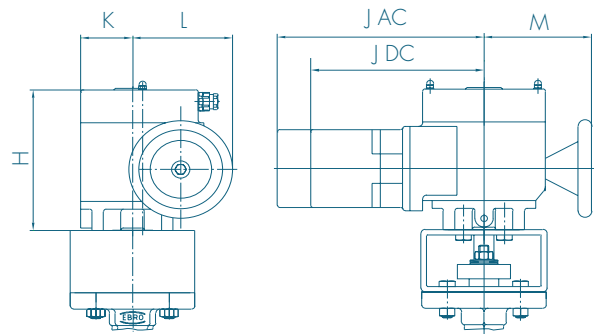

Subject to change without notice.

ACTUATORS HP 111

PNEUMATIC DOUBLE ACTING FOR PTFE-SEAT

DN [mm]	Size [in]	Actuator Type	H	J	K	L	Weight [kg]
50-100	2-4	EB 5	108	88	55	174	1,7
125-150	5-6	EB 6	123	103	62	208	2,6
200	8	EB 8	136	115	68	250	4,3
250	10	EB 10	155	135	79	312	6,8
300	12	EB 12	182	159	94	367	12,0
350-400	14-16	EB 265	232	152	76	390	18,0
450-500	18-20	EB 270	278	220	110	445	32,0
550	22	EB 280	278	220	110	600	42,0

FOR INCONEL-SEAT

DN [mm]	Size [in]	Actuator Type	H	J	K	L	Weight [kg]
50-80	2-3	EB 5	108	88	55	174	1,7
100	4	EB 6	123	103	62	208	2,6
125-150	5-6	EB 8	136	115	68	250	4,3
200	8	EB 10	155	135	79	312	6,8
250-300	10-12	EB 12	182	159	94	367	12,0
350	14	EB 265	232	152	76	390	18,0
400-450	16-18	EB 270	278	220	110	445	32,0
500-550	20-22	EB 280	278	220	110	600	42,0

The dimensioning of actuators refers to an operating pressure of 10 bar and a control air pressure of 6 bar.

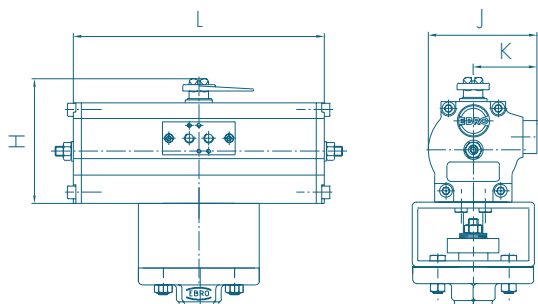

PNEUMATIC SPRING RETURN FOR PTFE-SEAT

DN [mm]	Size [in]	EBF Actuator	H	J	K	L	Weight [kg]
50-80	2-3	EB 5	108	88	55	273	3,0
100	4	EB 6	123	103	62	326	5,0
125	5	EB 8	136	115	68	389	7,7
150	6	EB 10	155	135	79	526	14,3
200	8	EB 12	182	159	94	656	25,4
250-300	10-12	EB 270	278	220	110	655	45,0
350-500	14-20	EB 280	278	220	110	1020	68,0

FOR INCONEL-SEAT

DN [mm]	Size [in]	EBF Actuator	H	J	K	L	Weight [kg]
50-80	2-3	EB 6	123	103	62	326	5,0
100	4	EB 8	136	115	68	389	7,7
125-150	5-6	EB 10	155	135	79	526	14,3
200	8	EB 12	182	159	94	656	25,4
250	10	EB 270	278	220	110	655	45,0
300-350	12-14	EB 280	278	220	110	1020	68,0

The dimensioning of actuators refers to an operating pressure of 10 bar and a control air pressure of 6 bar.

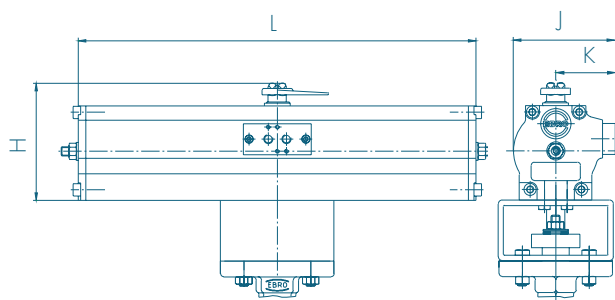

SWITCH BOX SERIES MSK/NSK

MSK: Switch Box with integrated micro limit switches.
NSK: Switch Box with integrated proximity switches.

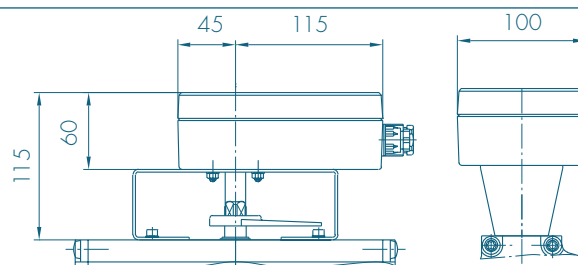

Subject to change without notice.

HIGH-PERFORMANCE BUTTERFLY VALVE HP 111

TORQUE

- The values specified are based on the initial breakaway torque. (disc disengages from seat, torque than drops).

DN [mm]	Size [in]	Operating Pressure							
		10 [bar]		16 [bar]		25 [bar]		40 [bar]	
		R-PTFE	Inconel	R-PTFE	Inconel	R-PTFE	Inconel	R-PTFE	Inconel
50-65	2-2½	27	35	28	42	30	58	31	66
80	3	28	55	30	65	34	90	38	100
100	4	51	90	61	100	80	120	93	140
125	5	63	150	83	172	95	220	125	285
150	6	125	170	136	220	168	300	220	360
200	8	205	350	260	430	280	505	*	*
250	10	485	505	550	620	600	860	-	-
300	12	584	740	700	970	855	1280	-	-
350	14	740	815	930	1050	1200	1370	-	-
400	16	1150	1530	1640	2240	2460	2900	-	-
450	18	1150	1700	1750	2500	2700	3500	-	-
500	20	1210	2010	1800	2760	2800	4260	-	-
550	22	3500	3750	4430	4550	6010	6800	-	-
600	24	4000	4500	4600	5740	6200	8080	-	-

* DN 200 PN 16 max. 25 bar

All Values in Nm

PRESSURE /TEMPERATURE DIAGRAM

- Pressure control line for GS-C25 body material and metal seat
- Pressure control line for 1.4408 body material and metal seat
- · - · - · - Pressure control line for R-PTFE-seat

The diagram illustrate the performance of the standard version of our valve type HP. Valves for higher pressure or deviating temperature are available upon request.

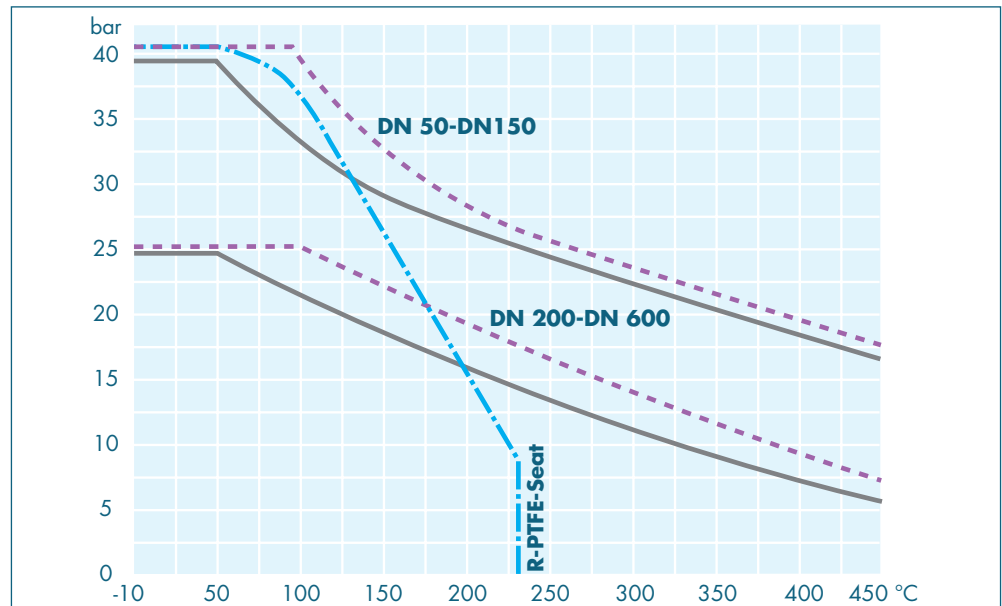

K_V-VALUES

- The K_V-value (m³ per hour) is the flow of water at a temperature of 5 °C to 30 °C (41 °F to 86 °F) Δp of 1 bar.
- The K_V-values specified are based on tests carried out by the Delft Hydraulics Laboratories, the Netherlands.
- Permissible velocity of flow
V_{max} 4,5 m/s for liquids and
V_{max} 70 m/s for gases.
- The throttle function is linear at an angle 30° to 70°.
- Avoid cavitation!

For further values, please contact our engineers.

DN [mm]	Size [in]	Opening angle							
		20°	30°	40°	50°	60°	70°	80°	90°
50	2	1,3	6	15	18	19	21	22	23
65	2½	1,5	7	18	22	23	24	25	25
80	3	7	30	50	68	82	97	113	115
100	4	22	60	97	119	164	199	223	251
125	5	45	100	152	195	256	346	452	493
150	6	63	109	162	250	391	588	814	845
200	8	96	168	301	509	742	1107	1581	1747
250	10	264	458	682	980	1421	2083	2882	2889
300	12	397	625	956	1368	1938	2778	3794	3940
350	14	460	720	1100	1650	2500	3400	4800	5400
400	16	550	870	1250	2000	3200	4800	6800	8080
450	18	730	1200	1800	3100	4600	6400	8400	10500
500	20	920	1600	2600	4100	6000	8500	12100	12800
550	22	1090	1950	3100	4600	7500	10200	14700	15300
600	24	1370	2250	3780	4950	9000	12500	17100	18500

Subject to change without notice.