

# CONTAINER VALVE BE 250/BE 300



Container valve BE 250 with drain bolt lock

## TECHNICAL DATA

Nominal diameter:	DN 250/300
Face-to-face:	EBRO works standard
Flange accommodation:	according to the connections in container building
Flange surface design:	DIN 2526, Form A-E, ANSI RF
Marking:	DIN EN 19
Tightness check:	DIN 3230 T3 BO, BN (Leakage Rate 1) ISO 5208, Category 3 API 598 Table 5 ANSI B 16-104, Class VI
Temperature range:	-20 °C to +160 °C (depending on pressure and medium)
Operating pressure:	max. 1 bar
Differential pressure:	max. $\Delta p$ 1 bar
Body:	Aluminium alloy
Seat:	EPDM (Ethylene propylene caoutchouc) NBR (Acrylonitrile butadiene rubber) FPM (Fluorocarbon caoutchouc) AU (Polyurethane)
Disc:	Stainless Steel

## FEATURES

- Shut-off valve for lugging under containers
- Aluminium body
- Suitable for conical containers
- Possibilities for hand operation:
  - drain bolt lock
  - tilting lever
  - engage lever Open/Close
- Multiple shaft bearing
- Maintenance-free
- Can be disassembled, material-specific recycling possible

## GENERAL APPLICATIONS

- Container building
- Silos



# CONTAINER VALVE BE 250/BE 300

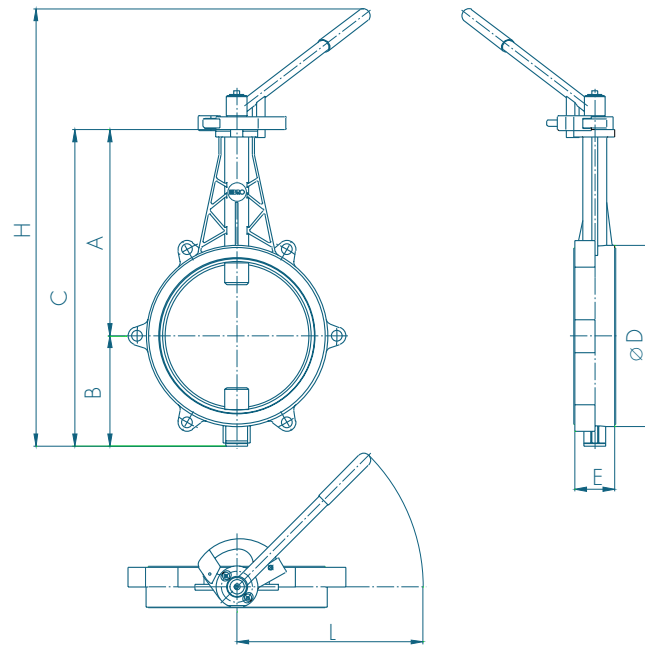

BE 250/300 with open/close lever

DN [mm]	Size [in]	Dimensions [mm]							Weight [kg]
		A	B	C	D	E	H	L	
250	10	346	185	531	304	67	778	384	6,2
300	12	274	226	500	355	78	742	384	8,9

Subject to change without notice.