

WAFER TYPE CHECK VALVE RSK



Technical data:

Nominal diameter:	DN 32 – DN 600
Face-to-face:	Works Standard
Flange accommodation:	DIN 2632/33 PN 10/16
Marking:	DIN EN 19
Tightness check:	DIN 3230 T3 BO, BN (Leakage Rate 1) ISO 5208, Category 3 API 598 Table 5 ANSI B 16-104, Class VI
Temperature range:	0 °C up to +200 °C, depending on sealing and body material.
Body:	Aluminium, AISI 304, AISI 316, Brass
Disc:	AISI 304, AISI 316
Attaching pins:	AISI 304, AISI 316
Seals:	NBR, FPM, EPDM, PTFE
Pressure range:	max. Δp 10 bar

FEATURES:

- Can be installed in any desired position
- Centering over the outside diameter of the body
- Sealing through O-rings
- Holder-eye for easy centering
- Extremely short face-to-face dimensions
- Materials can be changed among each other
- All constructions are available in spring-returned version
- Maintenance-free - simple mounting

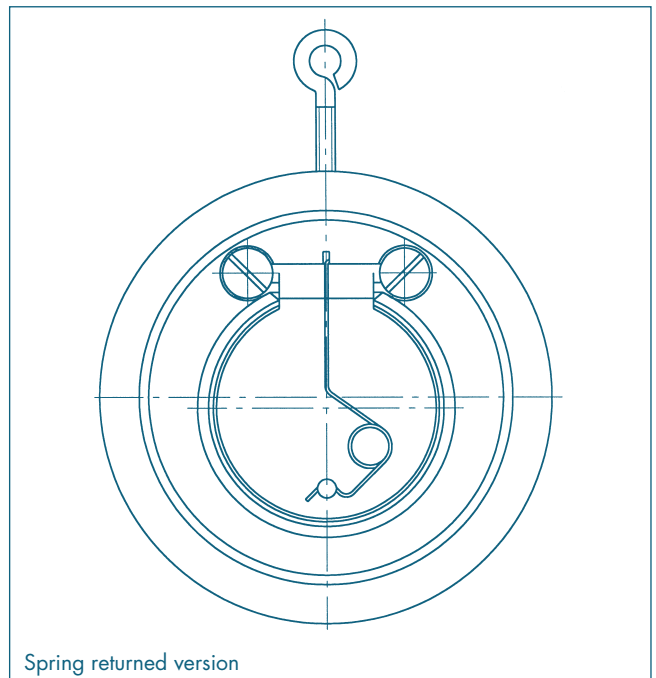

Subject to change without notice.

WAFER TYPE CHECK VALVE RSK

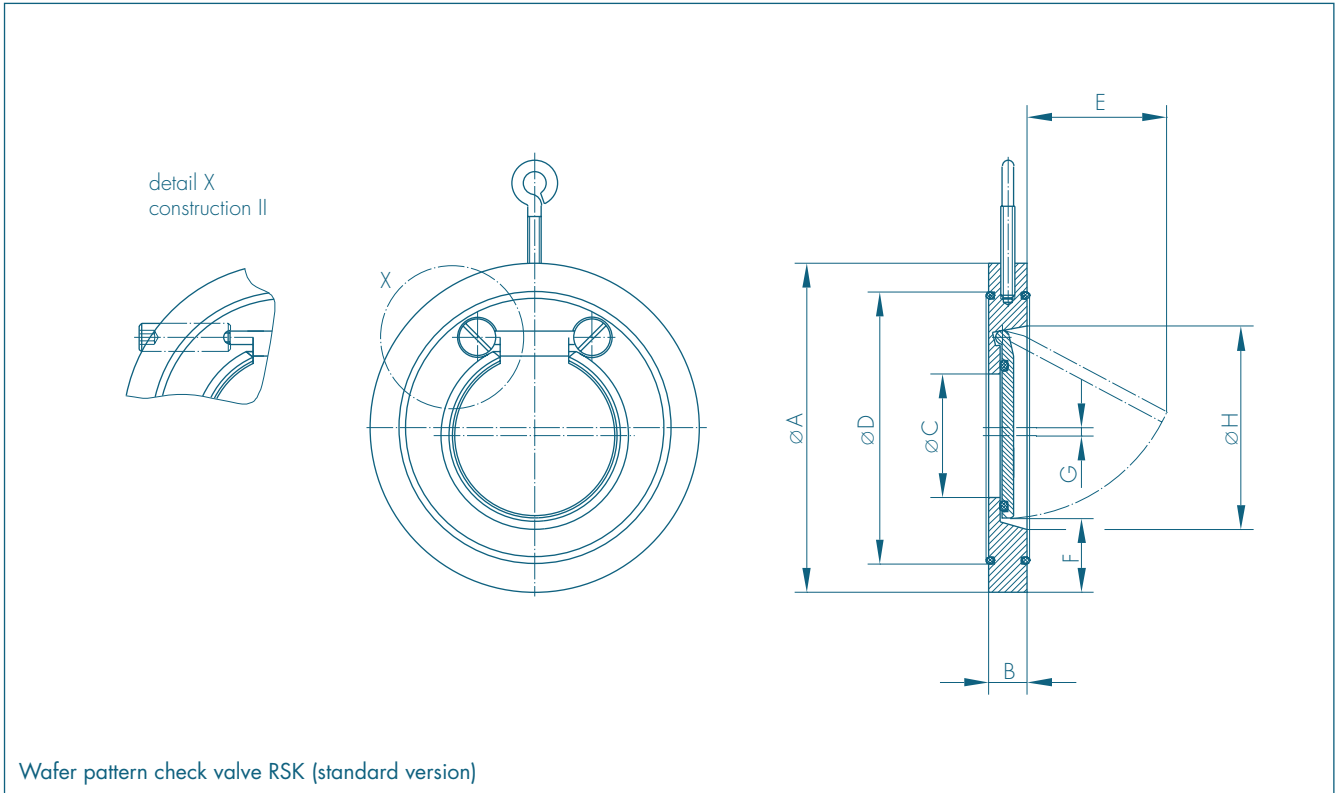

DN [mm]	Size [in]	Dimensions [mm]										Plastic Weight [kg]	Metal Weight [kg]
		A	B	Plastic spring returned	B	Metal spring returned	C	D	E	F	H ¹⁾		
32	1 1/4	85	15	15	15	15	18	59	22	25	37	0,1	0,6
40	1 1/2	95	16	16	16	16	22	72	25	28	43	0,1	0,9
50	2	109	18	18	17	17	31	86	37	29	54	0,17	1,1
65	2 1/2	129	20	20	17	17	40	105	50	31	70	0,22	1,5
80	3	144	20	20	17	17	54	119	61	32	82	0,26	1,8
100	4	164	23	33	21	21	70	146	77	31	106	0,37	3,0
125	5	195	23	23	18	22	92	173	94	35	131	0,5	3,4
150	6	220	26	26	20	26	105	197	100	40	159	0,74	5,4
200	8	275	35	35	22	29	154	255	152	38	207	1,4	7,7
250	10	330	40	40	26	36	192	312	180	41	260	2,4	13,2
300	12	380	45	45	32	43	227	363	215	41	309	3,52	23,3
350	14	440	49	49	38	47	266	416	245	54	341	5,1	38,0
400	16	491	65	65	44	53	310	467	285	55	392	7,3	52,5

The detail X shows the hand emergency actuation (can be delivered for an extra charge).

H = min. mounting-, pipe- inside diameter

¹ For reduced inside diameters, a bend sleeve is available.

Subject to change without notice.

WAFER TYPE CHECK VALVE RSK

PRESSURE LOSS DIAGRAM

The diagram shows the pressure loss Δp bar over the flow volume Q m³/h.
 The Kv-value (=Ql/min. $\Delta p = 1,0$ bar) is declared.
 For an conversion please note:
 $Ql/min. = 16,67 \times Q$ m³/h
 $k_v = 14,28 \times C_v = 17,09 \times f_v$

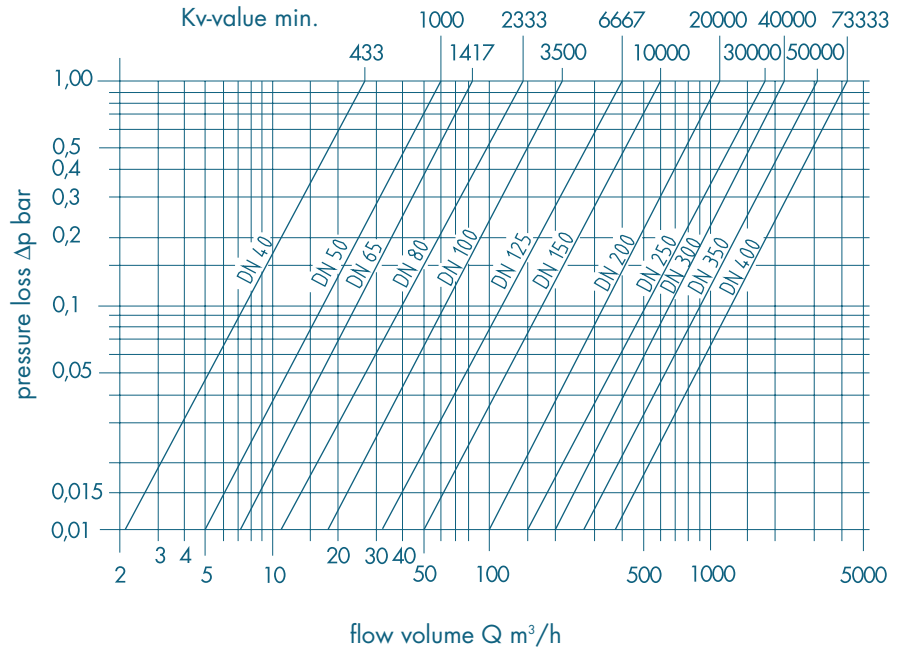

OPENING PRESSURE [mbar]

DN [mm]	Size [in]	Direction of flow							
		PVC version		PVC spring returned		Metal version		Metal spring returned	
		vert.	hor.	vert.	hor.	vert.	hor.	vert.	hor.
32	1 ¹ / ₄	4	1	12	7	-	-	-	-
40	1 ¹ / ₂	4	1	12	7	5	1	-	-
50	2	4	1	12	7	5	1	12	7
65	2 ¹ / ₂	4	1	12	7	5	1	12	7
80	3	7	1	20	7	12	1	12	7
100	4	7	1	20	7	12	1	20	8
125	5	7	1	20	7	12	1	20	8
150	6	7	1	20	7	20	1	20	8
200	8	12	1	27	8	20	1	27	8
250	10	12	1	27	8	20	1	27	8
300	12	12	1	27	8	25	1	27	8
350	14	16	1	35	9	25	1	35	9
400	16	16	1	35	9	25	1	35	9
500	20	16	1	35	9	-	-	-	-

Subject to change without notice.

WAFER TYPE CHECK VALVE RSK

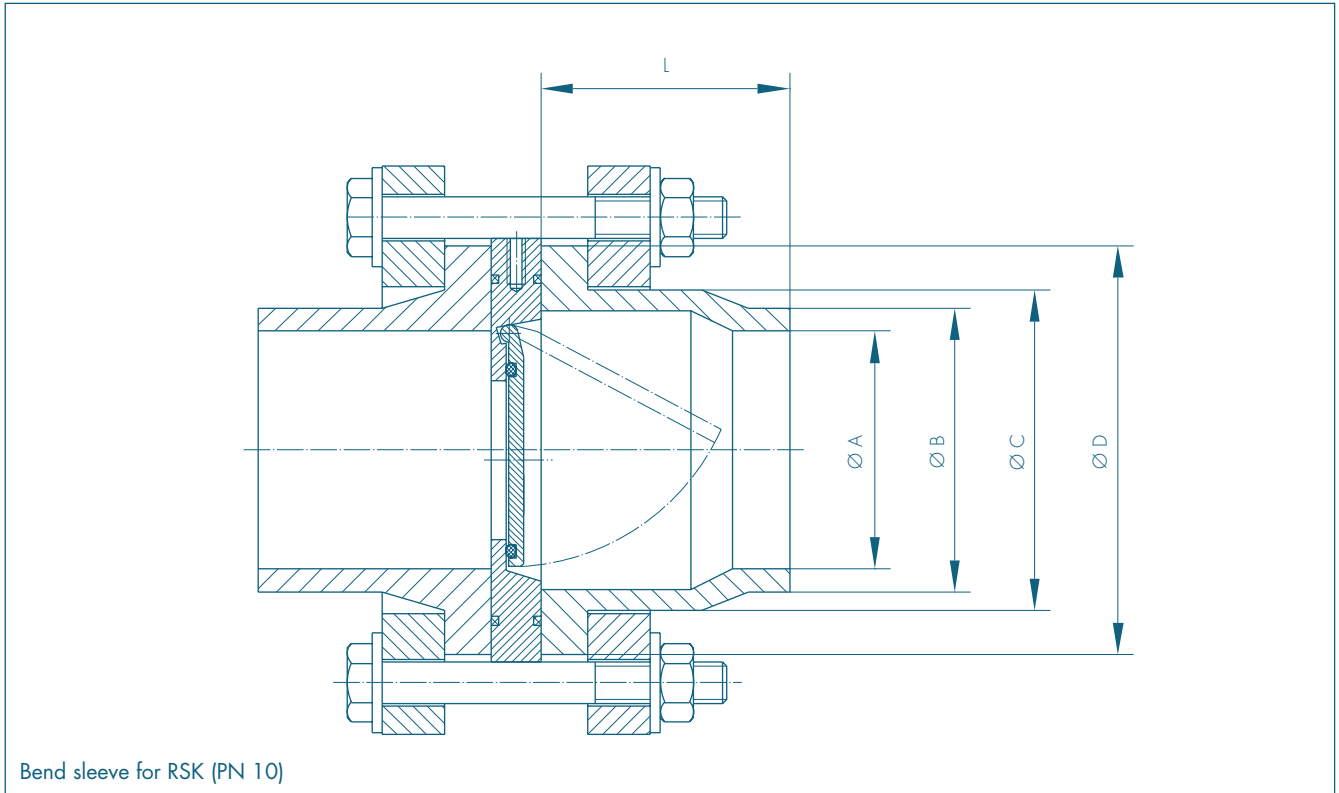

DN [mm]	Size [in]	Dimensions [mm]				
		A	B	C	D	L
32	1 1/4	35	40	50	80	45
40	1 1/2	44	50	61	90	48
50	2	55	63	77	105	54
65	2 1/2	66	75	91	125	58
80	3	79	90	109	140	72
100	4	97	110	132	160	92
125	5	124	140	166	190	100
150	6	141	160	189	215	120
200	8	199	225	249	270	165
250	10	248	280	293	325	195
300	12	280	315	337	385	250

Subject to change without notice.